

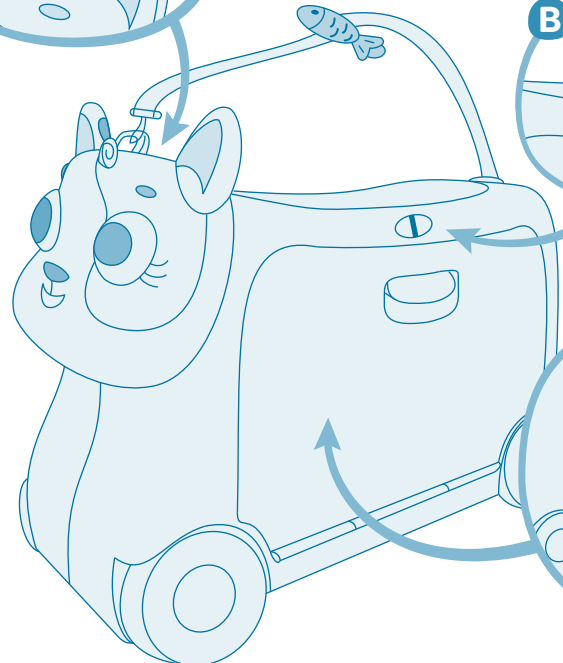

Gogo Ride-On™
Lolo™ Kid Suitcase

2-6
years

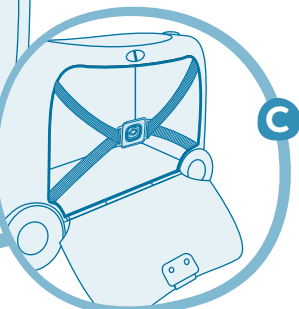
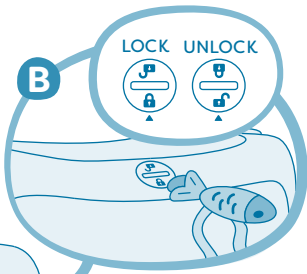

FUNCTIONS:

- A** Press buttons on ears to see the eyes light up and hear Meow sound.
- B** Use a regular coin or the fish on the strap to lock/unlock the suitcase.
- C** To make sure your most precious belongings stay put, use the interior elastic straps.

WARNING:
Not suitable for children under 24 months.
Long cord/Long chain. Strangulation hazard.

B. CAREFUL

- To keep this Gogo Ride-On™ suitcase safe, ALWAYS use on a smooth and flat surface. Never use near cars, roads, water, stairs, steep hills or on a bumpy road. To show off your best moves, wear shoes for extra grip!
- Remove all packaging before the first use.
 - Never allow more than one child at a time. It is designed for little ones aged 2 to 6 years and can hold up to 110 lbs (50kg.)
 - This toy should always be used with caution to avoid falling or bumping into things.
 - Misuse of this toy could result in injuring the rider or the spectators.
 - Make sure this toy is used under the supervision of a grown-up.
 - Make sure to remove the strap before riding on Lolo™!
 - Keep Lolo™ away from rain or puddles, as this may damage its electronic functions and/or the items inside the luggage.
 - Wipe clean only.

- 3 X AAA (1.5V) BATTERIES INCLUDED**
- Do not mix old and new batteries.
 - Do not mix alkaline, standard (carbon-zinc), or rechargeable batteries.
 - Dead batteries? Check out earth911.com to quickly find the recycling center nearest you.

REPLACING BATTERIES:

- Open battery compartment with Philips screwdriver.
- Flip up the module and insert 3 new AAA batteries.
- Flip down and close the battery cover with the screwdriver.

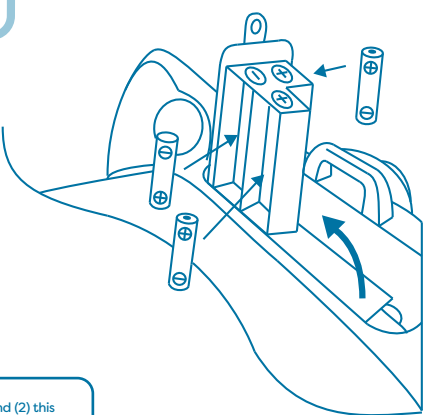
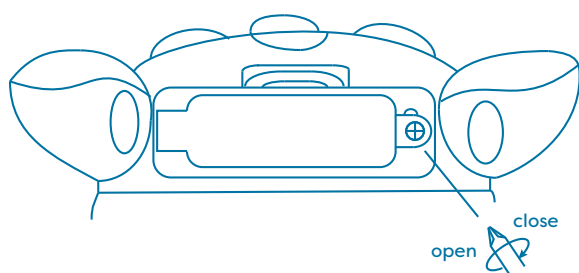

This device complies with Part 15 of the FCC Rules. Operation is subject to the following two conditions: (1) this device may not cause harmful interference, and (2) this device must accept any interference received, including interference that may cause undesired operation. Caution: changes or modifications not expressly approved by the party responsible for compliance could void the user's authority to operate the equipment. NOTE: This equipment has been tested and found to comply with the limits for a Class B digital device, pursuant to Part 15 of the FCC Rules. These limits are designed to provide reasonable protection against harmful interference in a residential installation. This equipment generates, uses and can radiate radio frequency energy and, if not installed and used in accordance with the instructions, may cause harmful interference to radio communications. However, there is no guarantee that interference will not occur in a particular installation. If this equipment does cause harmful interference to radio or television reception, which can be determined by turning the equipment off and on, the user is encouraged to try to correct the interference by one or more of the following measures:

- Reorient or relocate the receiving antenna.
- Increase the separation between the equipment and receiver.
- Connect the equipment into an outlet on a circuit different from that to which the receiver is connected.
- Consult the dealer or an experienced radio/TV technician for help.

© 2019 Maison Battat Inc.
Land of B. & Gogo Ride-On & Lolo & Just B. Just You. B. You are trademarks of Maison Battat Inc. Manufactured for Maison Battat Inc. 8440 Darnley Road, Montreal, P.Q. H4T 1M4
Designed by Maison Battat Inc.
Consumer Information Line: 1-866-665-5524
Colors may vary.
Visit us at www.mybtoys.com
Please remove all packaging materials before giving to children.



BX1759